

WAGNER



VECTOR GRIP AIRLESS SPRAY GUN

OWNER'S MANUAL

GB

Safety Precautions



Be safety-conscious! All local and national regulations governing ventilation, fire prevention, and operation must be observed.



HAZARD: Injection injury

A high pressure stream produced by this equipment can pierce the skin and underlying tissues, leading to serious injury and possible amputation. See a physician immediately.

DO NOT TREAT AN INJECTION INJURY AS A SIMPLE CUT! Injection can lead to amputation. See a physician immediately. Inform the physician of the type of coating material or cleaning agent with which the injury was caused.

The maximum operating range of the spray gun is 25 MPa / 250 bar fluid pressure.

- NEVER aim the gun at any part of the body.
- NEVER allow any part of the body to touch the fluid stream. DO NOT allow body to touch a leak in the fluid hose.
- NEVER put hand in front of the gun. Gloves will not provide protection against an injection injury.
- Never point the spray gun at anyone else.
- ALWAYS lock the gun trigger, shut the pump off, and release all pressure before servicing, cleaning the tip or guard, changing tip, or leaving unattended. Pressure will not be released by turning off the motor. The PRIME/SPRAY valve must be turned to PRIME to relieve the pressure. Refer to the Pressure Relief Pressure described in the pump manual.
- ALWAYS keep the tip guard in place while spraying. The tip guard provides some protection but is mainly a warning device.
- ALWAYS remove the spray tip before flushing or cleaning the system.
- The paint hose can develop leaks from wear, kinking and abuse. A leak can inject material into the skin. Inspect the hose before each use.
- NEVER use a spray gun without a trigger lock and trigger guard in place and in good working order.
- All accessories must be rated at or above the maximum operating pressure range of the airless sprayer. This includes spray tips, extensions, and hose.



HAZARD: Explosion hazard due to incompatible materials **Will cause severe injury or property damage.**

- Do not use materials containing bleach or chlorine.
- Do not use halogenated hydrocarbon solvents such as bleach, mildewcide, methylene chloride and 1,1,1 - trichloroethane. They are not compatible with aluminum.
- Contact your coating material supplier about the compatibility of material with aluminum.



HAZARD: General

This product can cause severe injury or property damage.

- Read all instructions and safety precautions before operating equipment.
- Never spray near sources of ignition; e.g. open flames, cigarettes — also cigars and pipes are sources of ignition —, sparks, hot wires and hot surfaces, etc.
- Wear respiratory equipment when spraying. The operator must be provided with a protective mask.

In order to prevent work related illness, the manufacturer's regulations for the materials, solvents, and cleaning agents used must be observed when preparing, working with and cleaning the unit. Protective clothing, gloves, eyewear, and, in certain cases, protective skin

cream are necessary to protect the skin.

- Follow the coating material and solvent manufacturer’s warnings and instructions.
- Extraction equipment should be installed by the user in accordance with local regulations.
- The objects being sprayed must be earthed.
- Before each use, check all hoses for cuts, leaks, abrasion or bulging of cover. Check for damage or movement of couplings. Immediately replace the hose if any of these conditions exist. Never repair a paint hose. Replace it with another grounded high-pressure hose.
- Pulling the trigger causes a recoil force to the hand that is holding the spray gun. The recoil force of the spray gun is particularly powerful when the tip has been removed and a high pressure has been set on the airless high-pressure pump. Therefore, when cleaning without tip set the pressure control valve to the lowest pressure.
- Use only manufacturer authorized parts. User assumes all risks and liabilities when using parts that do not meet the minimum specifications and safety devices of the spray gun manufacturer.



EXPLOSION PROTECTION IDENTIFICATION

X marking:

The spray gun corresponds with Ex II 2G IIC c T6 X and is, in accordance with Directive 2014/34/EU, suitable for use in explosion-hazardous areas—as of type Zone 1. Under certain circumstances, the unit itself may cause the Zone 1 condition to be in effect.

Any static-electricity discharge from the spray gun is to be diverted to the grounded high-pressure pump via the conductive high-pressure hose as stipulated.

The maximum surface temperature corresponds to the permissible material temperature. This and the permissible ambient temperature can be found in the Technical Data.

To avoid the generation of machine sparks, prevent impact stresses and any work on the unit with tools in the explosion-hazardous area.

Residual risks

Residual risks are risks, which cannot be excluded, even when equipment is used for the intended purpose.

In such cases the applicable areas of the actual residual risks will be pointed out using warning and/or prohibition signs.

Risk	Source / Cause	Impact	Preventative measures	Can occur during:
Injection injury	Atomized, high pressure stream of fluid	Severe injury or amputation	NEVER aim the gun at any part of the body	Setup, Operation
Explosion or fire	Static electricity or sparks	Severe injury	Use well ventilated area Ground the spray gun	Operation
Hazardous vapors	Hazardous vapors from spray material	Severe injury	Use well ventilated area Use mask	Operation

Technical Data

Max. operating pressure	25 MPa (250 bar)
Material inlet thread size	NPSM 1/4" (M16 x 1.5)
Diffuser thread size	7/8 - 14 UN-2A
Wetted parts material	High-grade steel, aluminum, PTFE, hard metal
Operating temperature range	40°F to 104°F (5°C to 40°C)
Maximum material temperature	109°F (43°C)
Maximum sound output	81 dB(A)*
Weight	663 g (1.4 lb.)

* Measurement location: 0.5 m away from the coating surface, 0.5 m behind the spray gun, spray pressure 12 MPa, tip size 0.021

Introduction

This airless spray gun is to be used for the high pressure atomization of liquid coating materials.

Using the Gun Trigger Lock

Always engage the gun's trigger lock when the gun is not in use.

1. To lock the trigger, push in the trigger lock from **left to right**, when looking at the rear of the gun.
2. To unlock the trigger, push the trigger lock from **right to left**, when looking at the rear of the gun.

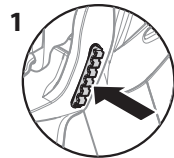

1 Gun locked
(gun will not spray)

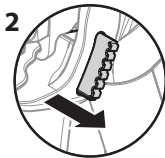

2 Gun unlocked
(gun will spray)



NEVER point the spray gun at yourself or anyone else.

Setup



Never attempt to assemble, change, or clean the gun, tip, or tip guard without first relieving pressure from the spray system. Follow the "Pressure Relief Procedure" in the sprayer's Owner's Manual.



Always use a tip safety guard for added protection against injection. Beware that the guard alone will not prevent injection. Never cut off tip guard! Always engage gun trigger lock when the gun is not in use. Before servicing equipment, consult Owner's Manuals and follow all warnings.

1. Set up the sprayer. Refer to the instructions in the sprayer's Owner's Manual.
2. Attach a grounded, airless spray hose to the material inlet on the gun. Using two wrenches (one on the gun and one on the hose), tighten securely.
3. With the tip and tip guard off the gun, start the sprayer. Flush and prepare the spray system according to the sprayer's Owner's Manual. Inspect the spray system to make sure that all fittings are secure and that there are no leaks.
4. Perform the "Pressure Relief Procedure" described in the sprayer's Owner's Manual.
5. Using a the end of the spray tip (5), insert the tip seal (3) and seal (4) into the back of the tip guard (2). Press in for final adjustment.
6. Insert the tip (1) into the slot on the tip guard.

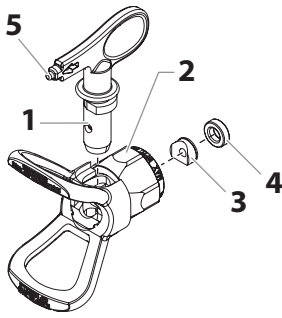

7. Thread the tip guard onto the gun. Position the tip guard in the desired spraying position, then tighten securely.



The arrow on the tip handle should be pointing in the forward direction for spraying.

Operation

1. Make sure the arrow on the tip handle is pointing in the forward direction for spraying.
2. Start the sprayer. Refer to the instructions in the sprayer's Owner's Manual.
3. Adjust the fluid pressure on the sprayer until the spray is completely atomized. Always spray at the lowest pressure necessary to get the desired results.



The spray tip determines the size of spray pattern and coverage. When more coverage is needed, use a larger tip instead of increasing fluid pressure.

4. To clear a clogged tip:
 - a. Rotate the tip 180° so that the arrow on the tip handle is pointing opposite the spray direction.
 - b. Trigger the gun once so that the pressure can blow the clog out.



Never pull the trigger more than once with the tip in the reverse position.

- c. Continue this procedure until the tip is clear of the clog.

Changing a Tip

Tips can be removed and replaced easily without disassembling the gun.



Never attempt to change or clean the tip or tip guard without first performing the "Pressure Relief Procedure."

1. Perform the "Pressure Relief Procedure" described in the sprayer's Owner's Manual.
2. Remove the tip from the slot on the tip guard.
3. Insert the new tip into the slot on the tip guard. The arrow on the tip handle should be pointing in the forward direction for spraying.

Removing the Seal and Tip seal

1. Remove the tip (1) from the tip guard (2).
2. Insert the tip handle through the front of the tip guard.
3. Push the tip seal (3) and tip seal retainer (4) out through the back of the tip guard.

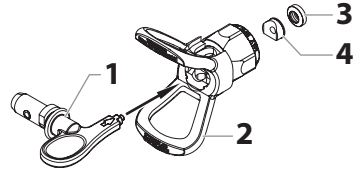

Identifying Tip Sizes

To identify tip sizes, use the following formula. A "517" tip size will be used in this example.

The first digit multiplied by two represents the size of the spray pattern when spraying 12" away from the work surface:

$$5 \times 2 = 10" \text{ spray pattern}$$

The second two digits represent the diameter of the orifice on the tip:

$$17 = .017" \text{ orifice}$$



Worn spray tips will adversely affect the spray pattern and result in reduced production, poor finish, and wasted material. Replace worn tips immediately.

Cleanup

Maintaining a clean gun is important to ensure trouble-free operation. Flush the gun after each use and store in a dry location. Do not leave the gun or any of its parts in water or solvents.



Special cleanup instructions for use with flammable solvents:

- Always flush spray gun preferably outside and at least one hose length from spray pump.
- If collecting flushed solvents in a one gallon metal container, place it into an empty five gallon container, then flush solvents.
- Area must be free of flammable vapors.
- Follow all cleanup instructions.



Attention

The sprayer, hose, gun and gun filter should be cleaned thoroughly after daily use. Failure to do so permits material to cake, seriously affecting the performance of the unit.



Always spray at the lowest possible pressure when the tip and tip guard have been removed. To clean the airless gun, hose and spray device, use only water or a suitable solvent. Static electricity buildup may result in a fire or explosion in the presence of flammable vapors. Hold the gun firmly against a metal container while flushing.

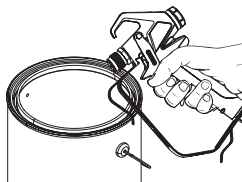

Maintenance

Follow all safety precautions as described in the Safety Precautions section of this manual before proceeding.



Refer to the Parts List section in this manual for part identification.

Replacing/Serviceing the Seal Assembly

If your spray gun leaks or spits at the tip when you release the trigger, replace the ball valve located on the packing seal assembly and reverse the seat located in the diffuser.

To replace the ball, order kit P/N 0538221 and follow the instructions included with the kit.

The entire packing seal assembly can also be replaced (less often than the ball valve). Follow the instructions below.



Never attempt to perform maintenance on the spray gun without first performing the "Pressure Relief Procedure."

1. Perform the "Pressure Relief Procedure" and disconnect the fluid hose from the gun.
2. Remove the end cap (1) and the packing spring (2) from the rear of the gun head.
3. Using a 3/8" socket, remove the packing seal assembly (3) from the rear of the gun head.

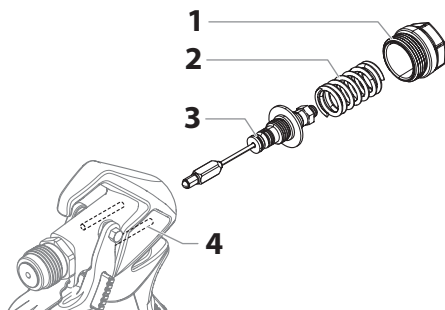

4. Soak the removed parts in the appropriate solvent and wipe clean.
5. Inspect the parts for wear or damage and use new parts during reassembly of the gun, when necessary.



Lubricate all packings and moving parts before reassembly with a lithium-based grease.

6. Make sure the two retractor pins (4) inside the gun head are still in the correct position.
7. Insert the packing seal assembly into the rear of the gun head and thread it by hand until it stops.
8. Using a 3/8" socket, tighten the packing seal assembly (3). Torque to 5 Nm (3.7 ft./lbs.).
9. Grease both ends of the packing spring (2) and place it over the packing seal assembly in the gun head.
10. Place the end cap (1) over the packing spring (2) so that the pilot inside the end cap seats inside the packing spring.
11. Push the end cap (1) toward the gun head while threading it into the gun head. Using a wrench, tighten the end (1) cap securely.

Reversing the Diffuser Seat

1. Using a wrench, loosen and remove the diffuser from the front of the gun head.
2. Remove the diffuser O-ring from the front of the gun head.
3. Remove the seat from the gun head. Flip it around and reinstall back into the gun head.
4. Reassemble the diffuser by reversing steps 1-2.

Replacing/Removing the Filter



The gun filter should be cleaned after every use.

1. Unclip the top of the trigger guard from the gun head.
2. Using the bottom of the trigger guard as a wrench, loosen and remove the handle assembly from the gun head.
3. Pull the old filter out of the gun head. Clean or replace.
4. Slide the new filter, tapered end first, into the gun head.
5. Thread the handle assembly into the gun head. Tighten with the trigger wrench.
6. Snap the trigger guard back onto the gun head.

Filter Chart

Part Number	Application	Filter Type	Filter Color
0034383	Synthetic resin, enamels, clean varnishes, stains, azures	Extra-fine	Red
0043235	Base coat enamels, primer enamels, fillers, marking paints, textured enamels	Fine	Yellow
0034377	Emulsions, latex paints, acrylic paints	Medium	White
0089323	Filler paints, large area surfaces	Coarse	Green

Accessories



In order to use any accessories with an F-thread (11/16") an adapter (P/N 0553300) is required.

Part Number	Description
0538228	Small grip kit
0538230	Large grip kit

Important notes on product liability

As a result of an EC regulation being effective as from January 1, 1990, the manufacturer shall only be liable for his product if all parts come from him or are released by him, and if the devices are properly mounted and operated.

If the user applies outside accessories and spare parts, the manufacturer's liability can fully or partially be inapplicable; in extreme cases usage of the entire device can be prohibited by the competent authorities (employer's liability insurance association and factory inspectorate division).

Only the usage of original WAGNER accessories and spare parts guarantees that all safety regulations are observed.

3+2 years guarantee for professional finishing

Wagner professional guarantee

(Status 01.02.2009)

1. Scope of guarantee

All Wagner professional colour application devices (hereafter referred to as products) are carefully inspected, tested and are subject to strict checks under Wagner quality assurance. Wagner exclusively issues extended guarantees to commercial or professional users (hereafter referred to as "customer") who have purchased the product in an authorised specialist shop, and which relate to the products listed for that customer on the Internet under www.wagner-group.com/profi-guarantee.

The buyer's claim for liability for defects from the purchase agreement with the seller as well as statutory rights are not impaired by this guarantee.

We provide a guarantee in that we decide whether to replace or repair the product or individual parts, or take the device back and reimburse the purchase price. The costs for materials and working hours are our responsibility. Replaced products or parts become our property.

2. Guarantee period and registration

The guarantee period amounts to 36 months. For industrial use or equal wear, such as shift operations in particular, or in the event of rentals it amounts to 12 months.

Systems driven by petrol or air are also guaranteed for a 12 month period.

The guarantee period begins with the day of delivery by the authorised specialist shop. The date on the original purchase document is authoritative.

For all products bought in authorised specialist shops from 01.02.2009 the guarantee period is extended to 24 months providing the buyer of these devices registers in accordance with the following conditions within 4 weeks of the day of delivery by the authorised specialist shop.

Registration can be completed on the Internet under www.wagner-group.com/profi-guarantee. The guarantee certificate is valid as confirmation, as is the original purchase document that carries the date of the purchase. Registration is only possible if the buyer is in agreement with having the data being stored that is entered during registration.

When services are carried out under guarantee the guarantee period for the product is neither extended nor renewed.

Once the guarantee period has expired, claims made against the guarantee or from the guarantee can no longer be enforced.

3. Handling

If defects can be seen in the materials, processing or performance of the device during the guarantee period, guarantee claims must be made immediately, or at the latest within a period of 2 weeks.

The authorised specialist shop that delivered the device is entitled to accept guarantee claims. Guarantee claims may also be made to the service centres named in our operating instructions. The product has to be sent without charge or presented together with the original purchase document that includes details of the purchase date and the name of the product. In order to claim for an extension to the guarantee, the guarantee certificate must be included.

The costs as well as the risk of loss or damage to the product in transit or by the centre that accepts the guarantee claims or who delivers the repaired product, are the responsibility of the customer.

4. Exclusion of guarantee

Guarantee claims cannot be considered

- for parts that are subject to wear and tear due to use or other natural wear and tear, as well as defects in the product that are a result of natural wear and tear, or wear and tear due to use. This includes in particular cables, valves, packaging, jets, cylinders, pistons, means-carrying housing components, filters, pipes, seals, rotors, stators, etc. Damage due to wear and tear that is caused in particular by sanded coating materials, such as dispersions, plaster, putty, adhesives, glazes, quartz foundation.
- in the event of errors in devices that are due to non-compliance with the operating instructions, unsuitable or unprofessional use, incorrect assembly and/or commissioning by the buyer or by a third party, or utilisation other than is intended, abnormal ambient conditions, unsuitable coating materials, unsuitable operating conditions, operation with the incorrect mains voltage supply/frequency, over-operation or defective servicing or care and/or cleaning.
- for errors in the device that have been caused by using accessory parts, additional components or spare parts that are not original Wagner parts.
- for products to which modifications or additions have been carried out.
- for products where the serial number has been removed or is illegible
- for products to which attempts at repairs have been carried out by unauthorised persons.
- for products with slight deviations from the target properties, which are negligible with regard to the value and usability of the device.
- for products that have been partially or fully taken apart.

5. Additional regulations

The above guarantees apply exclusively to products that have been bought by authorised specialist shops in the EU, CIS, Australia and are used within the reference country.

If the check shows that the case is not a guarantee case, repairs are carried out at the expense of the buyer.

The above regulations manage the legal relationship to us conclusively. Additional claims, in particular for damages and losses of any type, which occur as a result of the product or its use, are excluded from the product liability act except with regard to the area of application.

Claims for liability for defects to the specialist trader remain unaffected.

German law applies to this guarantee. The contractual language is German. In the event that the meaning of the German and a foreign text of this guarantee deviate from one another, the meaning of the German text has priority.

J. Wagner GmbH

Division Professional Finishing

Otto Lilienthal Strasse 18

88677 Markdorf

Federal Republic of Germany

CE Certificate of Conformity

The certificate is enclosed with this product. The certificate of conformity can be reordered from your WAGNER representative, quoting the product and serial number.

Part Number: 2367218

Note on disposal:

In observance of the European Directive 2002/96/EC on waste electrical and electronic equipment and implementation in accordance with national law, this product is not to be disposed of together with household waste material but must be recycled in an environmentally friendly way!



Wagner or one of our dealers will take back your used Wagner waste electrical or electronic equipment and will dispose of it for you in an environmentally friendly way. Please ask your local Wagner service centre or dealer for details or contact us direct.

Teileliste • Parts list • Liste de pièces

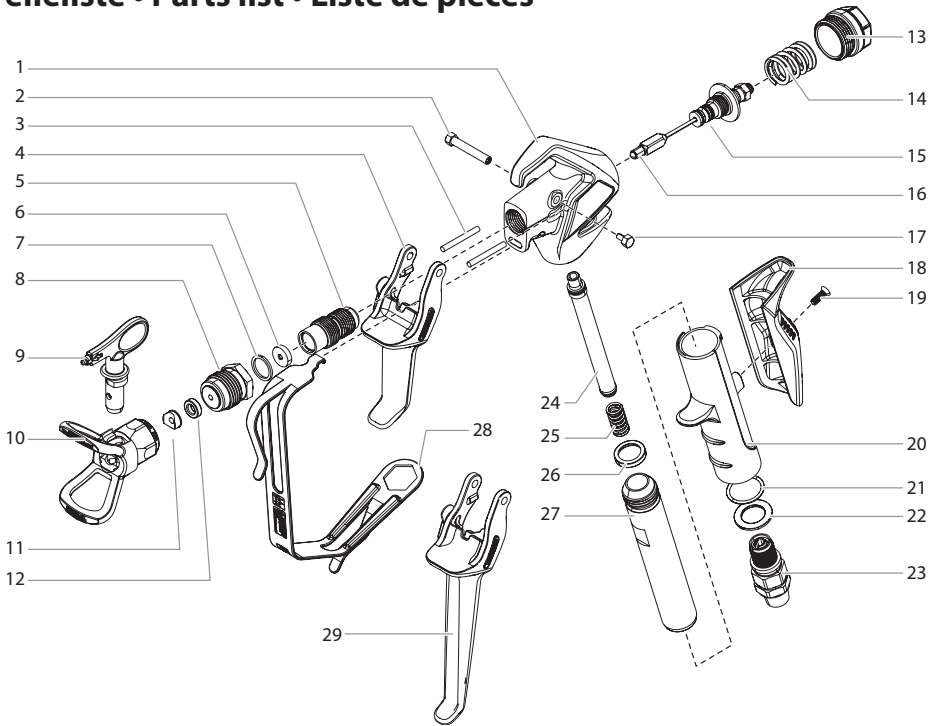

#	Teil-Nr Part # N° de pièce	Beschreibung	Description	Description
1	-----	Spritzpistolenkopf	Gun head	Tête du pistolet
2	0538306	Abzugschraube, lang	Trigger screw, long	Vis de détente, longue
3	0538305	Rückholstift (2)	Retractor pin (2)	Goupille de rétraction (2)
4	0538224	Abzug und Verriegelung, Pistole für 2 Finger (beinhaltet Posten 2 und 17)	Trigger and lock assembly, 2-finger gun (includes item 2 and 17)	Détente et ensemble de verrou, pistolet à deux doigts (inclut les articles 2 et 17)
5	-----	Oberes Gehäuse	Upper housing	Boîtier supérieur
6	594-033	Sitz	Seat	Assise
7	594-006	Diffusor-Rundring	Diffuser o-ring	Joint torique du diffuseur
8	0538322	Diffuser, 7/8"	Diffuser, 7/8"	Diffuseur, 7/8"
9	0553xxx	Düse, komplett (mit Teil 11-12)	Tip assembly* (includes items 11-12)	Buse (comprend les pièces 11 et 12)
10	0289390	Düsenschutz, 7/8"	Tip guard, 7/8"	Protection de buse, 7/8"
11	0297007	Düsendichtung	Tip seal	Joint de buse
12	0508423	Dichtung	Seal	Joint
13	0538323	Abschlussdeckel	End cap	Chapeau
14	0538324	Packungsfeder	Packing spring	Ressort de garniture

#	Teil-Nr Part # N° de pièce	Beschreibung	Description	Description
15	0538204	Packungsdichtung (mit Teil 16)	Packing seal assembly (includes item 16)	Joint de garniture (comprend les pièce 16)
16	-----	Kugelventil	Ball valve	Clapet à bille
17	580-513	Abzugschraube, kurz	Trigger screw, short	Vis de détente, courte
18	0538229	Handgriff, medium (beinhaltet Posten 19)	Handle grip, medium (includes item 19)	Poignée, moyenne (inclut l'article 19)
19	9805470	Schraube	Screw	Vis
20	0538315	Griff	Handle	Poignée
21	0538342	O-ring	O-ring	Joint torique
22	0538337	Unterlegscheibe	Washer	Rondelle
23	0538205	Drehgelenk (mit Teil 21-22)	Swivel (includes item 21-22)	Émerillon
24	0034377	Filter, mittlere Filterfeinheit	Filter, medium	Filtre moyen
25	0296343	Feder	Spring	Ressort (comprend les pièces 21 et 22)
26	560-038	Griffdichtung	Handle seal	Joint de poignée
27	0296344	Schlauch	Tube	Tuyau
28	0538320	Abzugaßbügel	Trigger guard	Protection de la détente
29	0538222	Abzug und Verriegelung, Pistole für 4 Finger (beinhaltet Posten 2 und 17)	Trigger and lock assembly, 4-finger gun (includes item 2 and 17)	Détente et ensemble de verrou, pistolet à quatre doigts (inclut les articles 2 et 17)
	0538228	Satz kleiner Handgriff (beinhaltet Posten 19)	Small grip kit (includes item 19)	Petite poignée (inclut l'article 19)
	0538230	Satz großer Handgriff (beinhaltet Posten 19)	Large grip kit (includes item 19)	Grande poignée (inclut l'article 19)
	0538227	Kugelaustausch-Set (beinhaltet Posten 16)	Ball replacement kit (includes item 16)	Trousse de remplacement de la bille (inclut l'article 16)